

MODEL NUMBER:

**LISN-CISPR25-70**

**Single path vehicle  
AMN (LISN)**



### DESCRIPTION:

The main application of the unsymmetrical single path AMN (artificial mains network) LISN-CISPR25-70 is the measurement of interference voltage in vehicles, aircrafts and ships in the HF-VHF range 0.1 – 150 MHz. The LISN-CISPR25-70 can also be used for bulk current injection (BCI) testing or for transient measurements according to ISO 7637-2.

The impedance characteristic is realized according to CISPR 16 / 25 and MIL-STD-461F (5  $\mu$ H + 1  $\Omega$ ) || 50  $\Omega$ . With the optional external capacitor CAP 10 it can be used for DO-160 and DEF-STAN-59 as well.

The continuous current rating is 70 A, for short time more than 100 A are possible. The EuT is connected to the wing terminals at the front panel. The mains terminals are on the backside.

### SPECIFICATIONS:

Frequency Range	100 kHz – 150 MHz
Max. con. current	70 A
Max. current (limited time)	100 A
Max. voltage DC	1000 V
Max. voltage 50/60 Hz	400 V
Max. voltage 400 Hz	300 V
Impedance	(5 $\mu$ H + 1 $\Omega$ )    50 $\Omega$ $\pm$ 10 %
Resistance of coil	< 5 m $\Omega$
Impedance at 50	4.2 m $\Omega$
Impedance at 400 Hz	13 m $\Omega$
Connector EuT	wing terminals, 7 mm
RF output	BNC (optional N)
Dimensions incl. connectors: width x height x depth	6,2x8,2x6,4 inches
Weight	4,18 lb
According to standard:	CISPR 16-1-2, Annex D2, D3 CISPR 25 MIL-STD-461F ISO 7637-2 Transients ISO 11452-4 BCI DO-160 (Airborne equipm.) DEF-STAN-59 ECE R10



## Schematic circuit diagram of the LISN-CISPR25-70

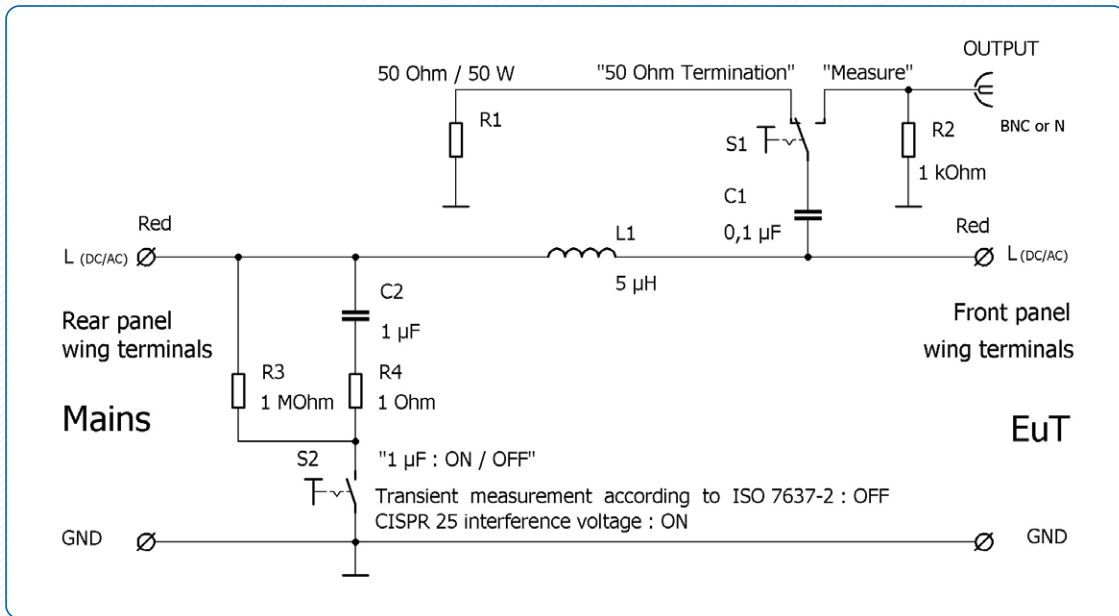

## Interference voltage measurements acc. to CISPR 25 or MIL-STD-461F:

Mains has to be connected to the back side. **The 1 µF capacitor must be switched on** to filter external disturbance and to provide best isolation values.

The DuT has to be connected to the front panel. The disturbance voltage is coupled to the BNC connector where it can be measured with an EMI receiver.

The switch at the front panel must be switched to "Measure". In most cases one AMN for each line (e.g. + and -) must be used. In this case one LISN-CISPR25-70 must be connected to the "+" line with its red terminals and another one to the "-" line, also to the red wing terminal.

The LISN of the line that is being measured has to be switched to "Measure", the other one has to be terminated by switching the front panel switch to "50 Ohm termination". The RF-reference ground must be connected to the GND-terminals. The 4 mm laboratory jacks at front- and back panel and the flat aluminium feet are electrically connected to the GND-terminals.

## Immunity tests with bulk current injection (BCI-tests):

The LISN-CISPR25-70 can be used for bulk current injection tests together with suitable current injection clamps.

The maximum continuous power rating is 50 W at the EuT-terminals. With a continuous power input of 50 W the LISN housing heats up to approx. 60 °C at the front panel. The operator must be aware of high temperatures. A sufficient air-circulation must be provided to avoid overheating of the LISN.

**The LISN must not be covered by all means to provide good air ventilation.**

A light smell of coating and insulating material may appear in the first hours of operation. Ensure proper ventilation of the test rooms. The smell will reduce after few hours of operating.

During bulk current injection tests danger may arise by high field strengths and temperatures (fire hazard!), therefore these tests must be carried out by qualified personnel only! The relevant safety precautions must be considered!

For BCI-tests the switch position "50 Ohm Termination" is used. The power injected at the EuT-terminals is converted to heat inside the 50 Ω / 50 W resistors.

**Please note:** The switch position "Measurement" routes the injected RF-power directly from the EuT-terminals to the BNC-output without any attenuation. Eventually **connected RF-measuring equipment may be damaged!**

## Transient measurements (ISO 7637-2)

The LISN-CISPR25-70 can be used to measure transients according to ISO 7637-2. The **1  $\mu$ F capacitor on the mains side could short transients and must be switched off** for this purpose.

### Calibration acc. to DO-160 or DEF-STAN-59:

For a calibration according to DO-160 or DEF-STAN-59 it is mandatory to connect a 10  $\mu$ F capacitance to the mains terminals. We offer a 10  $\mu$ F capacitor called CAP 10 for this purpose. It fits perfectly to the wing terminals of the LISN.

The built in 1  $\mu$ F capacitor must be switched off for DEF-STAN-59 or DO-160 measurements.



**CAP 10 mounted to a LISN**

### Notice:

Since the circuitry is according to CISPR 16 high ground currents do occur. Normally it is not possible to use a LISN on power lines with ground current safety switches (they disconnect power due to excessive ground current).

Either a special power line outlet without ground current safety switch must be installed (warning label required!), or an isolating power line transformer 1:1 has to be used.

In any case, provide reliable ground connection **to the LISN before connecting the power line**. Precise safety instructions must be provided to any user of the LISN.

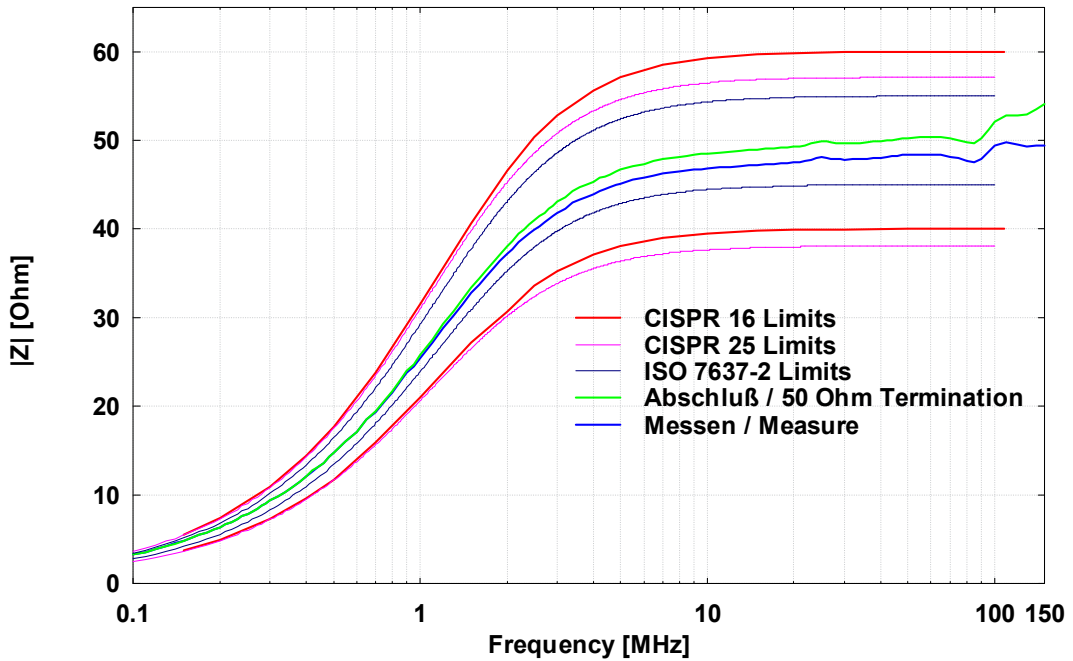

Magnitude of impedance at EuT-Terminals (Calibration adapter required),  
 BNC-Port terminated with 50 Ω, Mains terminals shorted

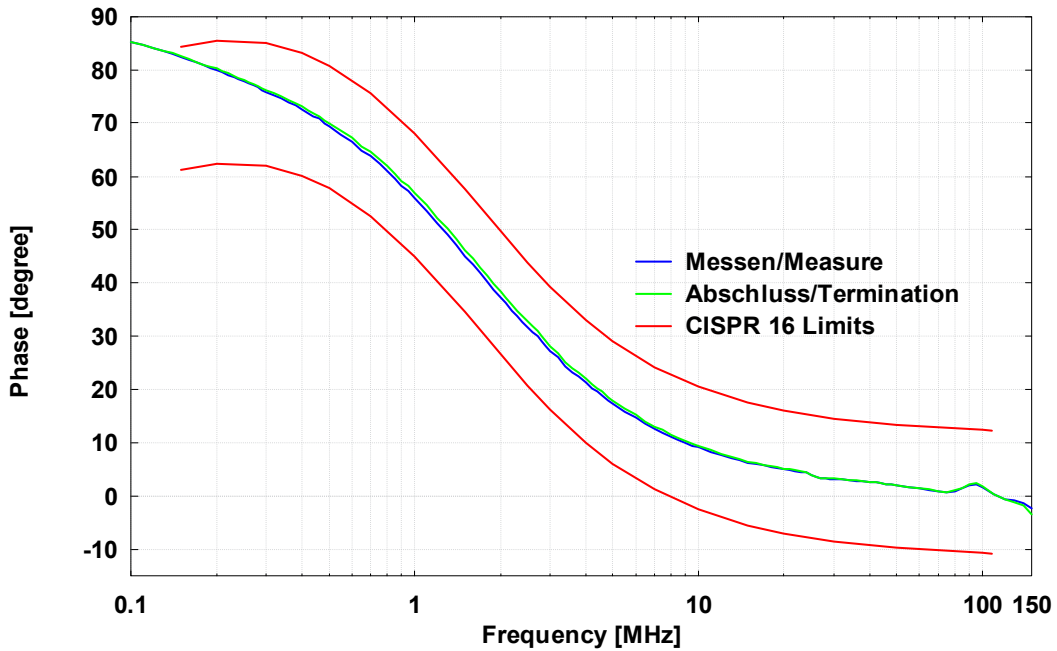

Phase of impedance at EuT-Terminals (Calibration adapter required),  
 BNC-Port terminated with 50 Ω, Mains terminals shorted

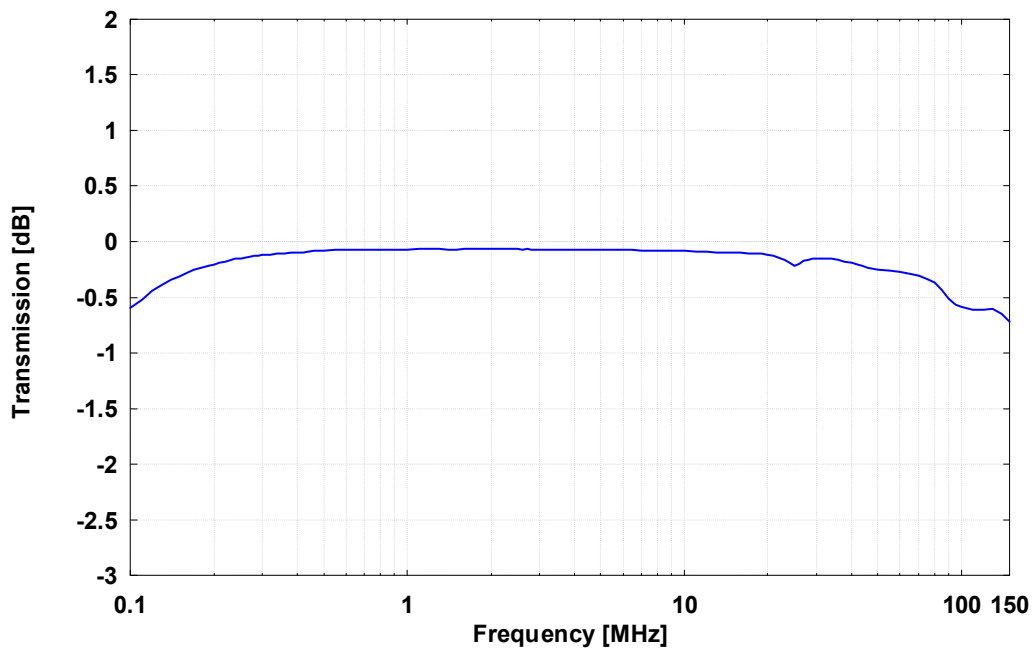

Voltage division ratio EuT-Terminals to BNC (Adapter required)

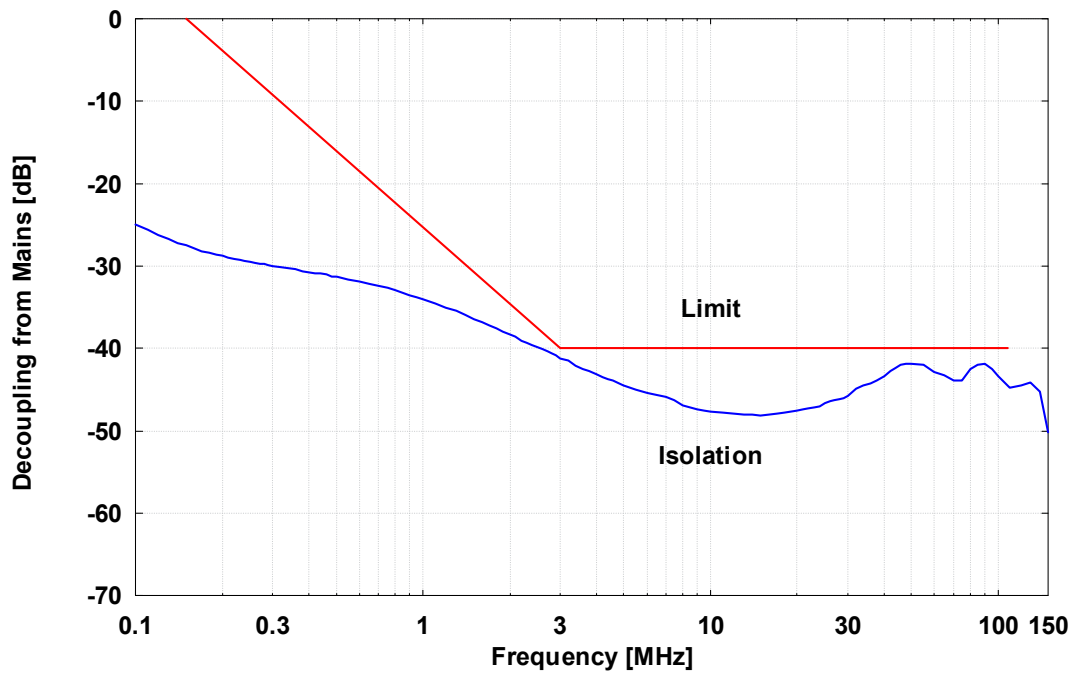

Decoupling (Isolation) from mains

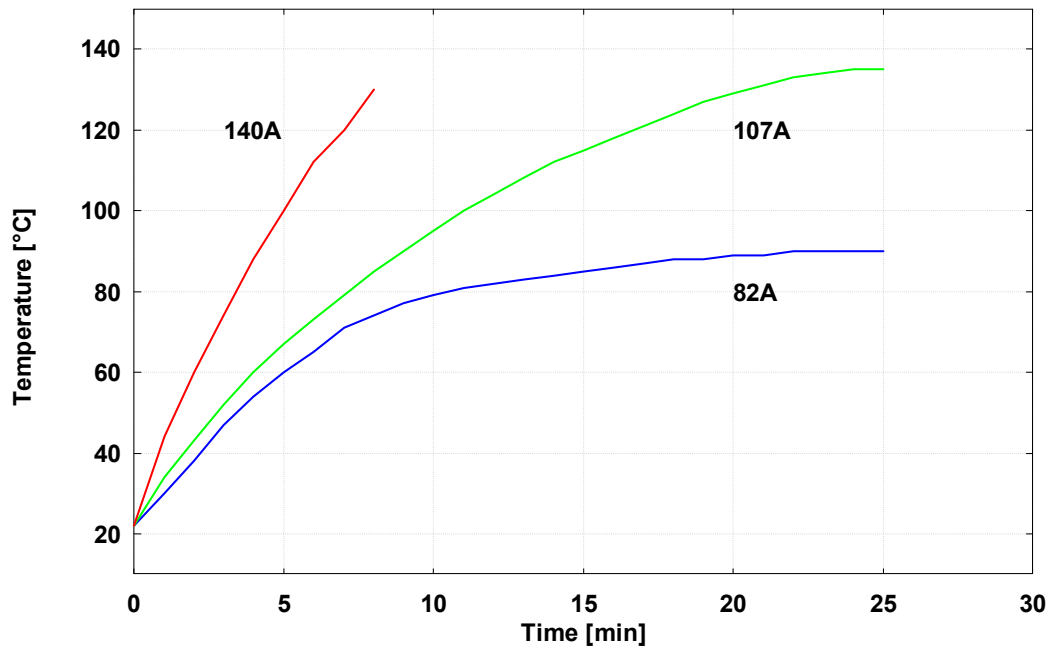

Heat Up Characteristics at continuous Current

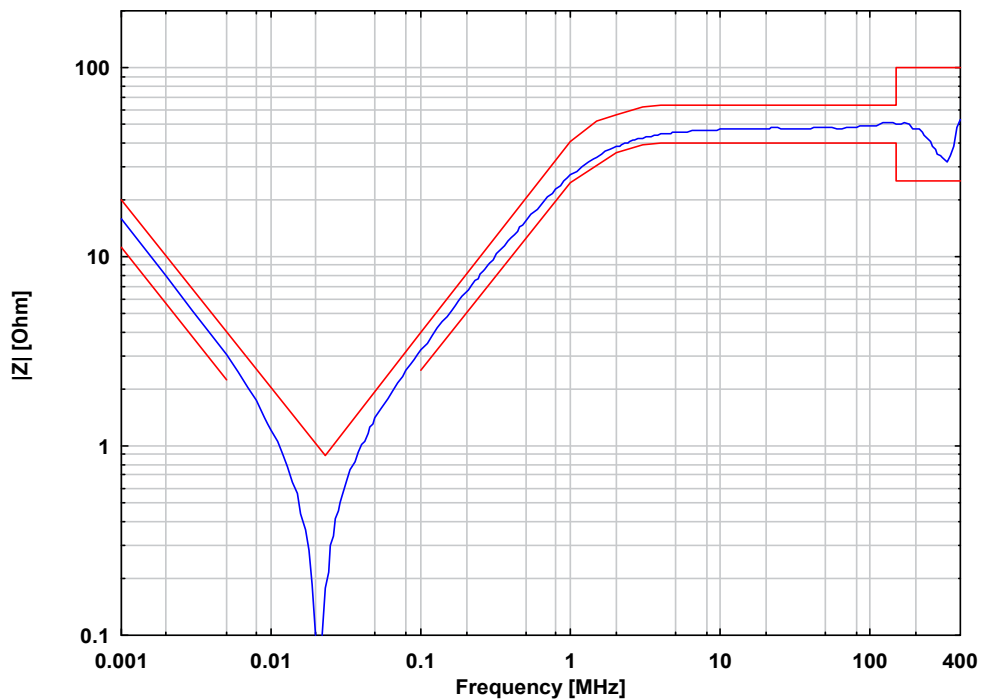

Magnitude of impedance at EuT-Terminals in acc. to DEF-STAN-59-411 (Calibration adapter required), BNC-Port terminated with 50  $\Omega$ , 10  $\mu\text{F}$  Capacitor across mains terminals

