

Active Monopole Antennas

OPERATION MANUAL



TABLE OF CONTENTS

INTRODUCTION	_____	3
SPECIFICATIONS	_____	5
OPERATING INSTRUCTIONS	_____	6
ANTENNA FORMULAS	_____	8
PREAMPLIFIER ALIGNMENT	_____	9
CALIBRATION	_____	11
MAINTENANCE	_____	12
WARRANTY	_____	13

INTRODUCTION

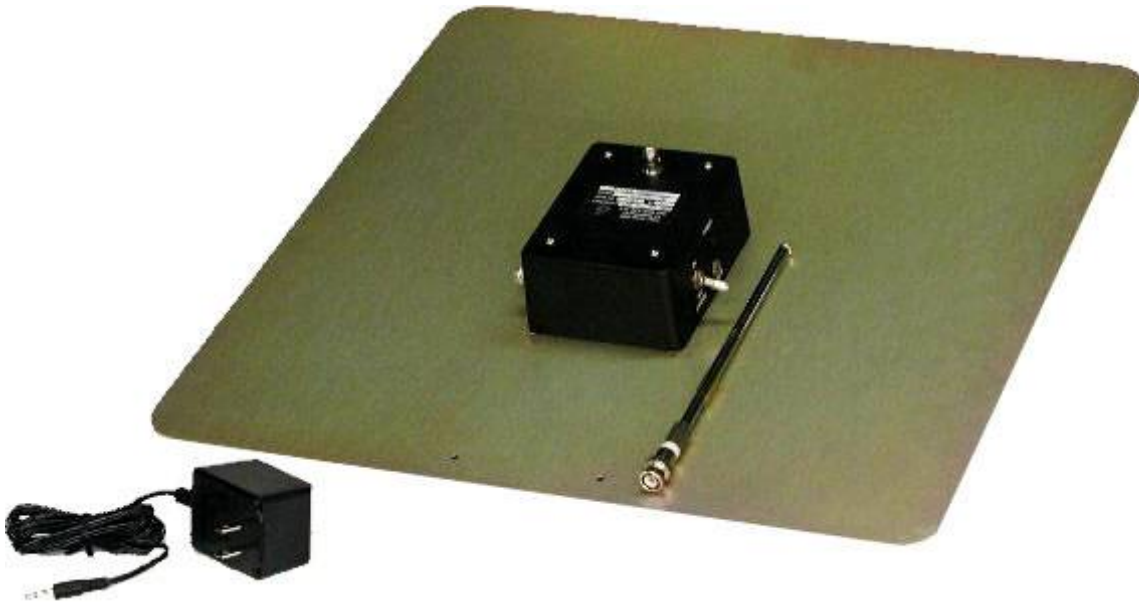

Model	Frequency Range	Part Number	Description
AMA60M9k	9 kHz – 60 MHz	2380	Active Monopole Antenna, Battery Powered
AMA60M100H	100 Hz – 60 MHz	2381	Active Monopole Antenna, Battery Powered

INTENDED PURPOSES

This equipment is intended for general laboratory use in a wide variety of industrial and scientific applications and designed to be used in the process of generating, controlling and measuring high levels of electromagnetic Radio Frequency (RF) energy. It is the responsibility of the user to assure that the device is operated in a location which will control the radiated energy such that it will not cause injury and will not violate regulatory levels of electromagnetic interference.

RANGE OF ENVIRONMENTAL CONDITIONS

This equipment is designed to be safe under the following environmental conditions:

Indoor use

Altitude: up to 2 km

Temperature: 5° C to 40° C

Maximum relative humidity: 80% for temperatures up to 31° C.
Decreasing linearly to 50% at 40° C

Pollution degree 2: Normally non-conductive with occasional condensation.

While the equipment will not cause hazardous condition over this environmental range, performance may vary.

SPECIFICATIONS

GENERAL DESCRIPTION

The EMC Shop active monopole antennas are active, general-purpose, receive-only antennas which cover the 100 Hz – 60 MHz frequency range. They are ideal for instantaneous bandwidth scanning (without tuning) of electric fields in its frequency range and can drive any receiver with an input impedance of 50 Ω. Each unit comes with a telescoping rod, ground plane with a high impedance matched preamplifier and battery charger. Review this manual and become familiar with all safety markings and instructions. Verify that the antenna impedance is compatible with the receiver impedance.

ANTENNA SPECIFICATIONS

AMA60M9k Active Monopole Antenna specifications:

Frequency Range	9 kHz – 60 MHz
Antenna Factor.....	0 dB/m
Flatness.....	+/- 0.5 dB from 20 kHz– 30 MHz +/- 5 dB whole range
Sensitivity.....	5 dB μ V/m @ 10 kHz -20 dB μ V/m @ 1 MHz
Dynamic Range.....	96 dB @ 10 kHz 122 dB @ 1 MHz
Saturation.....	87 dBuV/m
Output Connector Type.....	BNC(f)
Input Power.....	12 Vdc Battery
Weight.....	4.7 lbs. / 2.1 kg
Size (W x H x D).....	18" x 18" x 41" 46 cm x 46 cm x 104 cm

AMA60M100H Active Monopole Antenna specifications:

Frequency Range	100 Hz – 60 MHz
Antenna Factor.....	0 dB/m
Flatness.....	+/- 0.5 dB from 2 kHz – 30 MHz +/- 24 dB whole range
Sensitivity.....	5 dB μ V/m @ 10 kHz -20 dB μ V/m @ 1 MHz
Dynamic Range.....	96 dB @ 10 kHz 122 dB @ 1 MHz
Saturation.....	87 dBuV/m
Output Connector Type.....	BNC(f)
Input Power.....	12 Vdc Battery
Weight.....	4.7 lbs / 2.1 kg
Size (W x H x D).....	18" x 18" x 41" 46 cm x 46 cm x 104 cm

OPERATING INSTRUCTIONS

ASSEMBLY INSTRUCTIONS

To prepare the antenna for operation, attach the telescoping rod antenna element to the top of the high impedance preamplifier. Connect the rod antenna by pushing straight down on the female connector on top of the amplifier. Do not apply excessive sideways force, as this can cause the antenna center-pin to break. Do not operate the Monopole antenna with the Battery Charger connected.

SETUP INSTRUCTIONS

The amplifier and ground plane can be mounted to any tripod with a 1/4-20 attaching stud. Attach the rod antenna to the connector on the top of the amplifier. Extend the rod antenna to 41" (104 cm) above the ground plane. Connect the output BNC connector on the side of the amplifier to the input of a 50 Ω receiver or spectrum analyzer. Establish a ground connection to the ground plane if required by the test specification.

NOTE: The on/off toggle switch is a locking type to prevent accidental turn-on or turn-off. Pull out on the toggle handle and push up to turn the amplifier power on. Pull out and push down to turn it off.

The POWER indicator LED will illuminate and stay lit as long as the battery has sufficient voltage to power the preamplifier. If the LED does not illuminate, do not use the preamplifier until the battery has been recharged.

GENERAL USE INSTRUCTIONS

The calibration tables shown provide a listing of the frequency of operation and its antenna factor in dB/m. The field strength is the receiver voltage in dB μ V plus the antenna factor (refer to the antenna factor calibration) plus any cable loss. When making a measurement, mount the antenna on an appropriate mast or tripod. Ensure that the active monopole antenna is turned on and use the appropriate correction factors. The active monopole antenna is easy to set up and provides good reception with a minimal need for space. Its flat 0 dB antenna factor makes it a convenient choice when calculating the field intensity. The signal field strength is the receiver voltage in dB μ V plus the antenna factor (refer to the antenna factor calibration tables) plus any cable loss.

CHARGING THE BATTERY

Position the input voltage selector located next to the wall plug on the back of charger to the proper voltage (either 110 – 120 Vac, 60 Hz or 220 – 240 Vac, 50 Hz). Be sure to check the available voltage and adjust the voltage selector as needed before use. The amplifier ON-OFF switch must be in the OFF/CHARGE position to charge the battery. Every hour of charge will result in two hours of operation for up to 10 hours of charging. Charging for up to 24 hours will not damage the battery. Using the battery charger to operate the amplifier directly is not recommended.

REPLACING THE BATTERIES

Remove the four 6-32 flat head screws from the bottom of the ground plane. Disconnect the battery lead from the PC card. Re-connect the lead from the new battery pack to the PC card. Snug the four 6-32 flat head screws. Insure that the orientation of the amplifier box is that the input rod connector is facing toward the center of the ground plane.

ECF-10 (Equivalent Capacitance Fixture)

The ECF-10 is an equivalent capacitance fixture constructed per IEEE 291 and ARP 958. This is an indispensable tool used for gain adjustment and calibration of the active monopole antennas. The ECF-10 is used as a signal substitution source when calibrating the active monopole antennas. Refer to the alignment and calibration procedures below.

ANTENNA FORMULAS AND CALCULATIONS

A specific antenna factor is associated with each frequency. This number is to be added to the receiver reading (in dB μ V) to convert to field intensity in dB μ V/m.

EXAMPLE:

Assume the transmitter to be measured is operating at 1 MHz and the receiver reading indicates 44.0 dB μ V

AF (dB/m) = 0.1

Receiver reading (dB μ V) = 44 dB μ V

Cable loss (dB) = 0.7

Field Intensity = AF + receiver reading + cable loss

Field Intensity = 0.1 + 44.0 + 0.7

Field Intensity = 44.8 dB μ V/m

CALIBRATION

Preamplifier Alignment

Preliminary alignment is required on all manufactured active monopole antennas prior to placing the units in stock for sale. All preliminary test sheets and ITP will be maintained and a copy stored with the unit to be placed in stock.

Turn on the equipment and allow 15 minutes for warm-up.

Set up the equipment to 50 MHz center frequency, 10 MHz Span/DIV, 2 dB/DIV amplitude, 300 kHz resolution and 80 dB μ V reference amplitude on the spectrum analyzer.

Set the output level on the tracking generator to 72 dB μ V.

Connect the tracking generator to the spectrum analyzer as shown in Figure 3 and the 50 Ω load connected to the antenna signal output port (B).

Save the trace as trace A.

Connect the tracking generator cable to the fixture terminated with 50 Ω (A) and connect the spectrum analyzer cable to the signal output port (B) per Figure 3.

Adjust the resistor pots (R₆, R₇ and R₈ Figure 1) to match the following curve (Figure 2).

- R6 adjusts high-frequency gain
- R7 adjusts low-frequency gain
- R8 adjusts overall gain

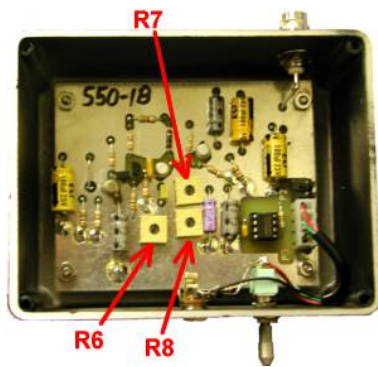

Figure 1

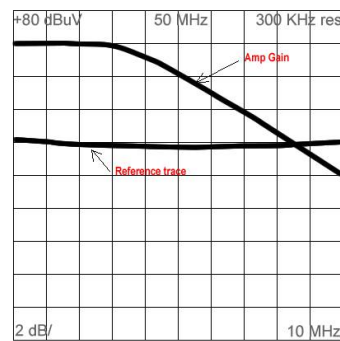

Figure 2

Verify that the low frequency cut off is below specification.

Records providing evidence that the required final inspection and tests are carried out shall be maintained and shall be available for review by the customer and third party inspectors. Such records include signed off ITPs, job cards, nonconformance reports, test reports and inspection reports, if any.

Measurement System Checks

MIL-STD-461E changed from the previous versions with the addition of making a pre-test calibration (measurement system checks) as part of the test procedure. When testing to the previous standards, one could go through an entire test suite with a faulty cable and never know it. This cable could adversely affect the results for one or many tests, depending on how often it was used.

The 10 pF capacitor (ECF-10) used with the rod antenna in the measurement system check simulates the capacitance of the rod element to the outside world. With the rod antenna, the electric field present induces a voltage in the rod that is applied to the preamplifier circuitry. One of the functions of the preamplifier is to convert the high impedance input of the antenna element to the 50 Ω impedance of the measurement receiver. The 10 pF capacitor ensures that the correct source impedance is present during the check.

For measurement system checks, establishing the correct voltage at the input to the 10 pF capacitor can be confusing. Since, the electrical length of the 104 cm rod is 0.5 meters, the conversion factor for the induced voltage at the input to the 10 pF capacitor is 6 dB/m.

If the limit at the measurement system check frequency is 34 dB μ V/m, the required field level to use for measurement system check is 6 dB less than this value or 28 dB μ V/m. The voltage level that must be injected is:

$$28 \text{ dB}\mu\text{V/m} - 6 \text{ dB/m} = 22 \text{ dB}\mu\text{V}$$

Since the input impedance at the 10 pF capacitor is very high, a signal source must be loaded with 50 Ω (termination load or measurement receiver) to ensure that the correct voltage is applied. A T-connector can be used with the signal source connected to the first leg, the 50 Ω load connected to the second leg, and the center conductor of the third leg connected to the 10 pF capacitor.

Active Monopole Calibration

The antenna factor for the rod antenna shall be determined by measuring the signal transfer characteristics of the matching device and assuming that the antenna is a short monopole with an infinite ground plane. Set up the monopole to be calibrated and the test equipment per Figure 3. Allow all equipment to warm up for 15 minutes.

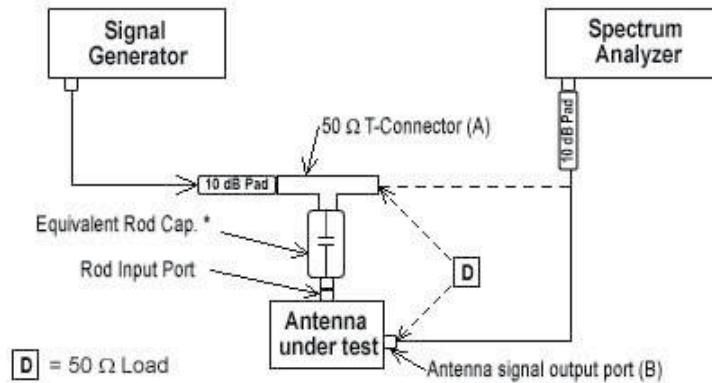

* Also referred to as a Dummy Antenna.

Figure 3

NOTES

If the VSWR of the receiver or signal generator is low, pads may not be needed or reduced to 6 dB or 3 dB.

With the equipment connected as shown and a 50 Ω termination on the T-connector (A), measure the received signal voltage V_L in $\text{dB}\mu\text{V}$ at the signal output port (B).

Leaving the RF output of the signal generator unchanged, transfer the 50 Ω termination to the signal output port (B) and transfer the receiver input cable to the T-connector (A). Measure the drive signal voltage V_D in $\text{dB}\mu\text{V}$.

Subtract V_L from V_D and add 6 dB to obtain the antenna factor (in dB) of the antenna.

Records providing evidence that the required final inspection and tests are carried out shall be maintained and shall be available for review by the customer and third party inspectors. Such records include signed off ITPs, job cards, nonconformance reports, test reports and inspection reports, if any.

NOTE – The signal generator does not need to be calibrated, but it shall be stable. The 50 Ω termination shall have low VSWR. The spectrum analyzer shall be calibrated and have low VSWR.

MAINTENANCE

To ensure reliable and repeatable long-term performance, annual re-calibration of your active monopole preamplifier by The EMC Shop experienced technicians is recommended. Our staff can recalibrate almost any type or brand of antenna.

For more information about our calibration services or to place an order for antenna calibration, visit our website at www.theemcshop.com or call 844.423.7435.

WARRANTY INFORMATION

The EMC Shop, LLC, warrants that our Antennas, Sensors and Probes will be free from defects in materials and workmanship for a period of three (3) years. All other products delivered under contract will be warranted for a period of two (2) years. Damage caused by excessive signals at the product's input is not covered under the warranty. The EMC Shop, obligation under this warranty shall be limited to repairing or replacing, Roseville, California, each part of the product which is defective, provided that the buyer gives The EMC Shop notice of such defect within the warranty period commencing with the delivery of the product by The EMC Shop.

The remedy set forth herein shall be the only remedy available to the buyer, and in no event shall The EMC Shop be liable for direct, indirect, incidental or consequential damages.

This warranty shall not apply to any part of the product which, without fault of The EMC Shop has been subject to alteration, failure caused by a part not supplied by The EMC Shop, accident, fire or other casualty, negligence, misuse or normal wear of materials.

Except for the warranty set forth above, there are no other warranties, expressed or implied, with respect to the condition of the product or it's suitability for the use intended for them by the buyer.

For prompt service, please contact our service department for a Return Material Authorization Number before shipping equipment back to us.